

**Vibrating Wire Embedment Strain Gauge**  
User Manual



Man142	6.1.0	06/08/14	P. Day	Andy Small	Chris Rasmussen
<b>Manual No.</b>	<b>Revision</b>	<b>Date</b>	<b>Originator</b>	<b>Checked</b>	<b>Authorised for Issue</b>

# Contents

<b>Section 1 : Introduction</b>	<b>3</b>
<b>Section 2 : Equipment Supplied</b>	<b>4</b>
<b>Section 3 : Installation</b>	<b>5</b>
3.01 Installation in Concrete	5
3.02 Installation in Pre-cast blocks	7
<b>Section 4 : Protection of the Installation</b>	<b>8</b>
<b>Section 5 : Cable Routing and Protection</b>	<b>9</b>
<b>Section 6 : Monitoring</b>	<b>10</b>
<b>Section 7 : Data Interpretation</b>	<b>11</b>
<b>Section 8 : Temperature Effects</b>	<b>13</b>
<b>Section 9 : Troubleshooting Guide</b>	<b>14</b>
<b>Appendix A. Vibrating Wire Data</b>	<b>15</b>
<b>Appendix B. Troubleshooting Flowchart</b>	<b>16</b>
<b>Appendix C. CE Declaration</b>	<b>17</b>

## **Section 1 : Introduction**

---

Embedment Strain Gauges were developed by the British Transport & Road Research Laboratory to measure the internal strain in concrete structures. These waterproof gauges were developed in conjunction with Imperial College, London and incorporate the latest materials and techniques to make these gauges suitable for use in hostile conditions.

The nature of the instrument dictates that it is used to measure changes in strain (i.e. change in length per unit length).

The gauges are designed for use in installations where they are cast directly into the mass of the concrete structure. The pre-casting of the gauges into briquettes is recommended only where it can't be avoided.

## Section 2 : Equipment Supplied

---

Strain Gauges come supplied at pre-set readings dependent on the expected magnitude and direction of strains to be recorded.

Each gauge is supplied with a user specified length of cable moulded to the gauge sensing coil and a securing clamp. The cable can be spliced to other cables for routing to a terminal location. Cables can be routed over distances in excess of 1000 metres without degradation of signal.

Each gauge is supplied with a thick walled silicon rubber sleeve over each barrel (see Figure1) to protect the gauge barrel when it is tied to support bars during mounting.

Although gauges are checked prior to leaving Soil Instruments, damage can occur during transit. It is suggested that the gauges are visually checked immediately upon receipt. Additionally it is prudent to check the operation using a vibrating wire readout device to ensure steady readings, if an audio signal is available on the readout device this can give a good indication of the quality of the signal.



Prior to installation secure the coil assembly to the gauge using the securing clamp as shown above.

Before installation, a note should be made of the batch factors for the Strain Gauges for future data interpretation.

## Section 3 : Installation

---

The gauges are supplied sealed and pre-tensioned; no adjustment is necessary or possible. It is good practice to connect a readout to the gauge and ensure that the reading in free-air is stable and around the mid-range position. Gentle pressure applied to the gauge ends (i.e. small compression) should cause the  $F^2/1000$  reading to decrease.

The approximate mid position reading of the strain gauge is as follows:

830 Hz

690  $F^2/1000$  (Linear)

12038 Period units  $\times 10^7$

For sweep excitation readout units set the sweep range to 400 – 1200 Hz.

### 3.01 Installation in Concrete

The gauge can be installed in concrete in one of two ways; either by direct casting following attaching the gauge to, or between rebar, or by pre-casing into a concrete block which is then cast into the main concrete pour.

When affixing gauges to rebar for direct encasing into concrete, care must be taken to avoid over range forces being applied to the gauge end blocks by the speed and/or weight of concrete being poured. Do not tie the gauge too tightly to the rebar as this can move during pour and or curing and thus damage the gauge. If placing the gauge between rebar, please note the following:-

- Wrap self-amalgamating or a few turns of plastic (insulating) tape around the gauge where the soft wire ties will contact it to act as a shock absorber.
- Use only soft iron wire (as used by rebar erectors) and make at most 3 turns around the gauge, each 3-4 cm from the end blocks either side of the coil.
- Loop the wire (by twisting) between the gauge and the rebar, either side to allow for some expansion movement.

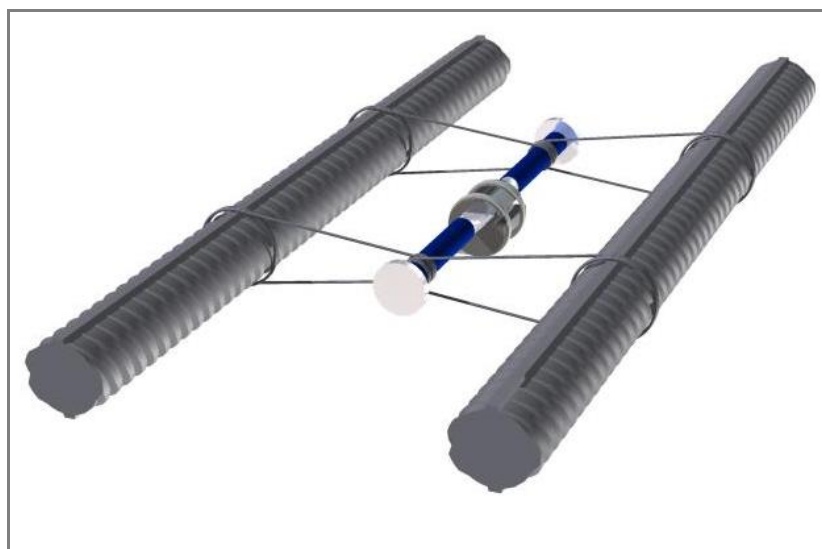

**Above; soft iron wire used to secure the gauge between reinforcing bars.**

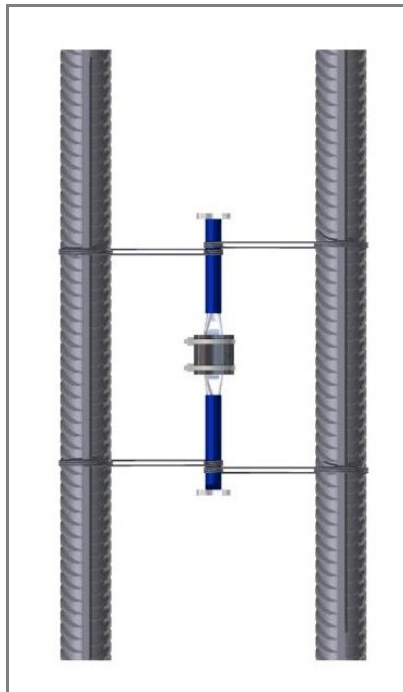

**Above; soft iron wire used to secure the gauge between reinforcing bars, Plan View.**

As an alternative to the above, small rebar sections, cut to length can be used to replace the soft steel wire with cable ties attaching these short lengths to the gauge and the main rebar. If this method is selected under no circumstances over tighten the cable ties so that no movement is allowed. An indicative picture is below.

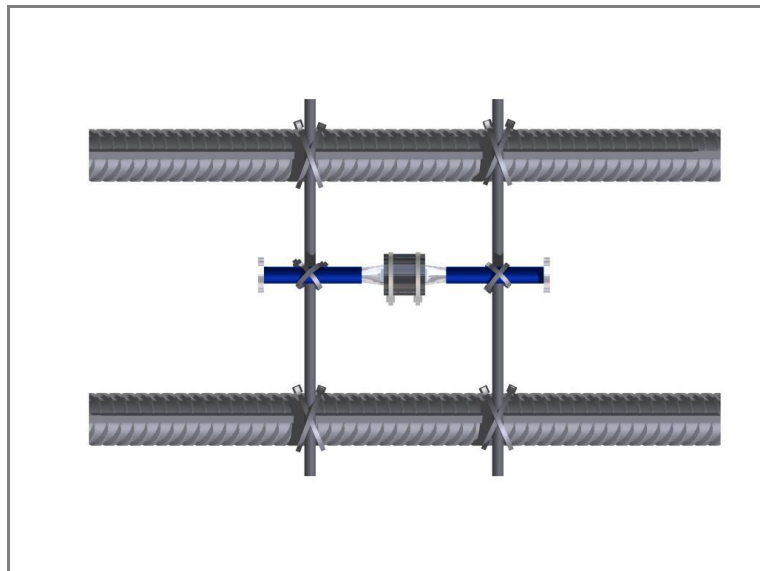

## 3.02 Installation in Pre-cast blocks

An alternative to fixing to rebar, is to pre-cast the gauge into a block of concrete prior to this being cast into the main concrete pour. This method takes more time, but does protect the gauges better during the main pour.

To install in this way, follow the steps below:-

- Fabricate a mould for the desired size of block
- Mix the concrete, ensuring the mix is the same as that which will be used for the main pour. Fill the mound and position the gauge in the middle of the fill.
- Do not cure for more than 3 days, or less than one day
- Place blocks in position in main pour – note comments on cable protection to follow in section 4

### **TABLE INDICATING SUGGESTED DIMENSIONS FOR SUPPORT BARS**

Refer to Figure 1

Gauge Length	'A'	'B'
150 mm	90 mm	8 mm

**INFORMATION**      **If the reinforcement spacing exceeds 3 x "A" then bar size "B" should be increased.**

The gauge positions should be marked, if possible on the reinforcement cages, and the cable route indicated.

**IMPORTANT**      **the final position of the gauge should be accurately recorded since this detail will be required for interpretation of its readings.**

## **Section 4 : Protection of the Installation**

---

All efforts must be taken to protect the gauge during concreting without significantly altering the reinforcement performance.

Where the gauge is installed in a vulnerable position good practice is to spray the area with marker paint as a warning and/or cover the area with fine wire mesh.

It may be necessary to fix additional reinforcement steel around the gauge position to offer protection during concreting though this could affect subsequent gauge readings.



## **Section 5 : Cable Routing and Protection**

---

Having established and marked the preferred route of the cables and decided upon the type of cabling arrangement to be adopted, begin running the cables from the gauges furthest from the readout location.

Where cables are not to be ducted, they should be strapped to the reinforcement, in a position where they are least likely to be damaged, using strong tape or cable ties. Cable should be supported every 400-500mm and care should be taken to avoid over stretching the cables, especially where movement/loading could take place when placing the cage.

The reinforcement bars can be used to protect the cables; for example by running the cables under the bars to reduce the risk of damage where vibrating pokers are to be used.

Where significant movement could take place, the cable ties should be left a little slack and sufficient cable left free and positioned so that it cannot be damaged.

Where cables are to exit from a concrete structural element, they should be protected by a short length of plastic duct. This will reduce the risk of the cable shearing off where it emerges from the concrete.

Once the cables have been fixed a full set of readings should be recorded for each instrument.

## **Section 6 : Monitoring**

---

Since the gauges are used to record changes in data and not absolute data, the stage when the "Base" or "Zero" reading is recorded is flexible.

The reading recorded after the gauge has been fixed and prior to concreting is useful for record purposes only.

Where the effects of concrete curing are to be observed, the Base reading should be recorded soon after the concrete has been placed and where necessary, compacted. All other operations, such as removal of steel pile casing, should have been completed before the Base reading is recorded.

Where loading tests are to be performed, the Base reading for the test data should be recorded just prior to the beginning of the test.

Data from Vibrating Wire instruments can be recorded in 3 formats; Period, Linear or Engineering Units. The required format should be established prior to any test beginning and remain consistent for the duration of the monitoring program.

The Soil Instruments Model 1030 & 1050 Readout/Loggers requires the Base reading to be recorded in Period units for automatic calculation of the applicable Engineering units. (See the Readout/Logger Operation Manual for full details).

A monitoring schedule should be established by the engineers responsible for the structure, so that the monitoring personnel are aware of the data gathering requirements.

## Section 7 : Data Interpretation

---

Data from strain gauges is generally presented in micro strain ( $\mu\varepsilon$ ) where strain is the ratio of the change in length per unit length:-

$$\left(\frac{\Delta L}{L}\right) \text{ Practical K factor} = 34080 \text{ (Gauge calibration constant)}$$

Conversion of Period and Linear Units to micro-strain is carried out using either of the formulae detailed below;

### **Period Units**

$$\mu\varepsilon = K * \left[ \frac{10^7}{(T_1)^2} - \frac{10^7}{(T_0)^2} \right] * B$$

Where;  $\mu\varepsilon$  = Change in strain in micro-strain  
 $K$  = Gauge Calibration Constant  
 $T_0$  = Base reading in Period units x  $10^7$   
 $T_1$  = Current reading in Period units x  $10^7$   
 $B$  = Batch Factor supplied with each gauge

Please note: when  $\frac{10^7}{(T_1)^2} - \frac{10^7}{(T_0)^2}$  is positive the resultant strain is tensile.

### **Linear Units**

$$\mu\varepsilon = (K (F_1 - F_0) \times 10^{-4}) \times B$$

Where  $\mu\varepsilon$  = Change in micro-strain  
 $K$  = Gauge Calibration Constant  
 $F_0$  = Base reading in  $f^2/1000$  units  
 $F_1$  = Current reading in  $f^2/1000$  units  
 $B$  = Batch Factor supplied with each gauge

Please note: when  $(F_1 - F_0)$  is positive the resultant strain is tensile.

The calculation of Load in a member using data from strain gauges is often complex. The fundamental problem is determining the composite Young Modulus (E) of the member, since it is often difficult to accurately determine the properties of the in-situ materials.

Once a Young Modulus is calculated, the following equations can be used to calculate the loading on the structural member at the location of the Strain Gauge.

Force (F) = Stress (S) x Area (A)  
Where A = Cross sectional area in m<sup>2</sup>  
Where F units = Newton's  
Where S units = N/m<sup>2</sup>

Stress (S) = Young Modulus of Elasticity (E) x Strain ( $\epsilon$ )  
Where E units = N/m<sup>2</sup>

### **Example calculation**

Steel pipe outside diameter = 1.016m  
Steel pipe inside diameter = 0.984m  
Calculated change from the strain gauges = 54.688  $\mu\epsilon$   
Young Modulus of Elasticity of the steel pipe = 200,000,000,000 N/m<sup>2</sup>

$$\begin{aligned}\text{Stress} &= E \times \epsilon \\ &= 200,000,000,000 \times 0.000054688 \\ &= 10937600 \text{ N/m}^2\end{aligned}$$

$$\begin{aligned}\text{Area} &= \pi r^2 \\ &= \pi \times (\text{outside diameter} / 2)^2 - \pi \times (\text{inside diameter} / 2)^2 \\ &= \pi \times (1.016 / 2)^2 - \pi \times (0.984 / 2)^2 \\ &= \pi \times (0.508)^2 - \pi \times (0.492)^2 \\ &= \pi \times 0.258064 - \pi \times 0.242064 \\ &= 0.810732 \text{ m}^2 - 0.760466 \text{ m}^2 \\ &= 0.050266 \text{ m}^2\end{aligned}$$

$$\begin{aligned}\text{Force} &= S \times A \\ &= 10937600 \times 0.050266 \\ &= 549789.4\text{N}\end{aligned}$$

## Section 8 : Temperature Effects

---

The curing of concrete can generate large temperature changes. It is therefore best practice to record temperature when you record strain readings. You can then use the temperature data as well as strain data to analyse the behaviour of the structure.

Temperature induced expansions and contractions can cause real changes in stress in the concrete if the concrete is restrained, these are superimposed on other load related stresses.

Differences between the coefficient of expansions of the concrete and that of the steel in the strain gauge itself give rise to an apparent change in strain in the concrete. This apparent change can be corrected for using the equation below.

$$\Delta\mu\varepsilon \text{ corrected} = \Delta\mu\varepsilon + (TC_g - TC_c)x(Temp_1 - Temp_0)$$

Where:

$\Delta\mu\varepsilon$  is the change in strain,

$TC_c$  is the thermal coefficient of concrete in  $\mu\varepsilon / ^\circ\text{C}$

$TC_g$  is the thermal coefficient of the gauge:  $12.2 \mu\varepsilon / ^\circ\text{C}$

$Temp_1$  is the current temperature

$Temp_0$  is the initial temperature

## Section 9 : Troubleshooting Guide

---

If a failure of any vibrating wire transducer or its electrical cable is suspected, the following steps can be followed. The transducers themselves are sealed and cannot be opened for inspection. The "Troubleshooting Flowchart" should also be followed if any instrument failures are suspected.

The steps below and the Troubleshooting Flowchart are applicable generally to any vibrating wire instrument.

### **Step 1**

Before any of the following steps are followed, the readout unit should be used to verify the stability of the reading and the audio signal from the portable logger should be heard. The period reading from the transducer should not vary by more than  $\pm 3$  units and the audio signal should be crisp and of a consistent tone and duration. An unstable (wildly fluctuating) reading from a transducer or an unsteady audio signal are both indications of possible problems with instruments, or their related electrical cables.

**Important:** If a portable data logger is giving faulty readings or audio signals from all transducers, a faulty readout unit must be suspected. Another readout unit should be used to check the readings from the transducers and Soil Instruments Ltd should be consulted about the faulty readout unit.

Before proceeding to Steps 2 and 3, if possible the continuity should be checked between conductors and earthing screen of the electrical cable. If continuity exists, a damaged cable is confirmed.

### **Step 2**

The resistance across the two conductors of the electrical cable should be checked. This can be done using a multimeter device across the two exposed conductors if the cable has not been connected to a terminal cabinet, or can be done just as easily across the two conductors if the instrument has been connected to such a terminal (or Data Loggers).

The resistance across the two conductors should be approximately of the order of  $80\Omega$  to  $180\Omega$ . The majority of these resistances arise from the transducer and the remainder from the electrical cable connected to the transducer.

### **Step 3**

If the resistance across the two conductors is much higher than the values quoted in "Step 2" (or is infinite), a damaged cable must be suspected.

### **Step 4**

If the resistance across the two conductors is much lower than the values quoted in "Step 1" (say  $80\Omega$  or less) it is likely that cable damage has occurred causing a short in the circuit.

### **Step 5**

If the resistance is within the values quoted in "Step 1" (i.e.  $80\Omega$  to  $180\Omega$ ), AND no continuity exists between conductor and earth screen and on checking the reading from the transducer, it proves to be still unstable or wildly fluctuating, it must be assumed that the integrity of the circuit is good. A faulty transducer must be suspected and Soil Instruments Ltd should be consulted.

**TIP** If the location on site of cable damage is found, the cable can be spliced in accordance with recommended procedure with suitably qualified personnel.

## Appendix A. Vibrating Wire Data

---

**Frequency Units (f):** The tension of a wire can be measured by registering the frequency (note) at which it naturally vibrates. If the wire is "plucked" electronically the frequency at which it vibrates can be measured. The most common units used to express frequency are Hertz (Hz) or Kilohertz (KHz).

The disadvantage of these units is that there is no "linear" conversion from Hertz to "change in wire tension".

**Linear Units (L):** In order to overcome the problem of a linear conversion described above, the frequency value can be squared, thereby rendering it linear, but quite large. To reduce its size it is often divided by 1000 (or multiplied by  $10^{-3}$ ). The expression  $f^2/1000$  (or  $f^2 \times 10^{-3}$ ) is the most commonly adopted as a "linear" digital output.

**Period Units (P):** Electronic devices and digital technology often utilise the "counter" function available in some common circuits.

Period Units represent the time taken for the wire to vibrate over one full oscillation, expressed in seconds. Due to the very small size of the number generated most equipment manufacturers display the unit multiplied by 10000000 (or  $10^{-7}$ ).

The relationship between Period Units and frequency units is expressed as 
$$P \propto \frac{1}{\text{Frequency}}$$

Period units are, therefore, convenient to measure but do not have a linear relationship to "change in wire tension".

**Calibration Constants:** Each instrument is supplied with a Calibration Constant value, to convert the raw data into engineering units.

The value of the calibration constant will vary depending upon the engineering units into which the data is to be converted and the readout units. For example, the data from piezometers may convert into Kg/cm<sup>2</sup>, mH<sub>2</sub>O, Bar, Psi, etc., and, therefore, the Calibration Constant for each will be different.

Some instruments have "Generic" Calibration Constants and others are calibrated to generate the Constant. The constant is generated by using the following calculation.

$$\text{Constant (K)} = \frac{\text{Range}}{\text{Reading @ Full Range} - \text{Reading @ Range Zero} \times 10^4}$$

## Appendix B. Troubleshooting Flowchart

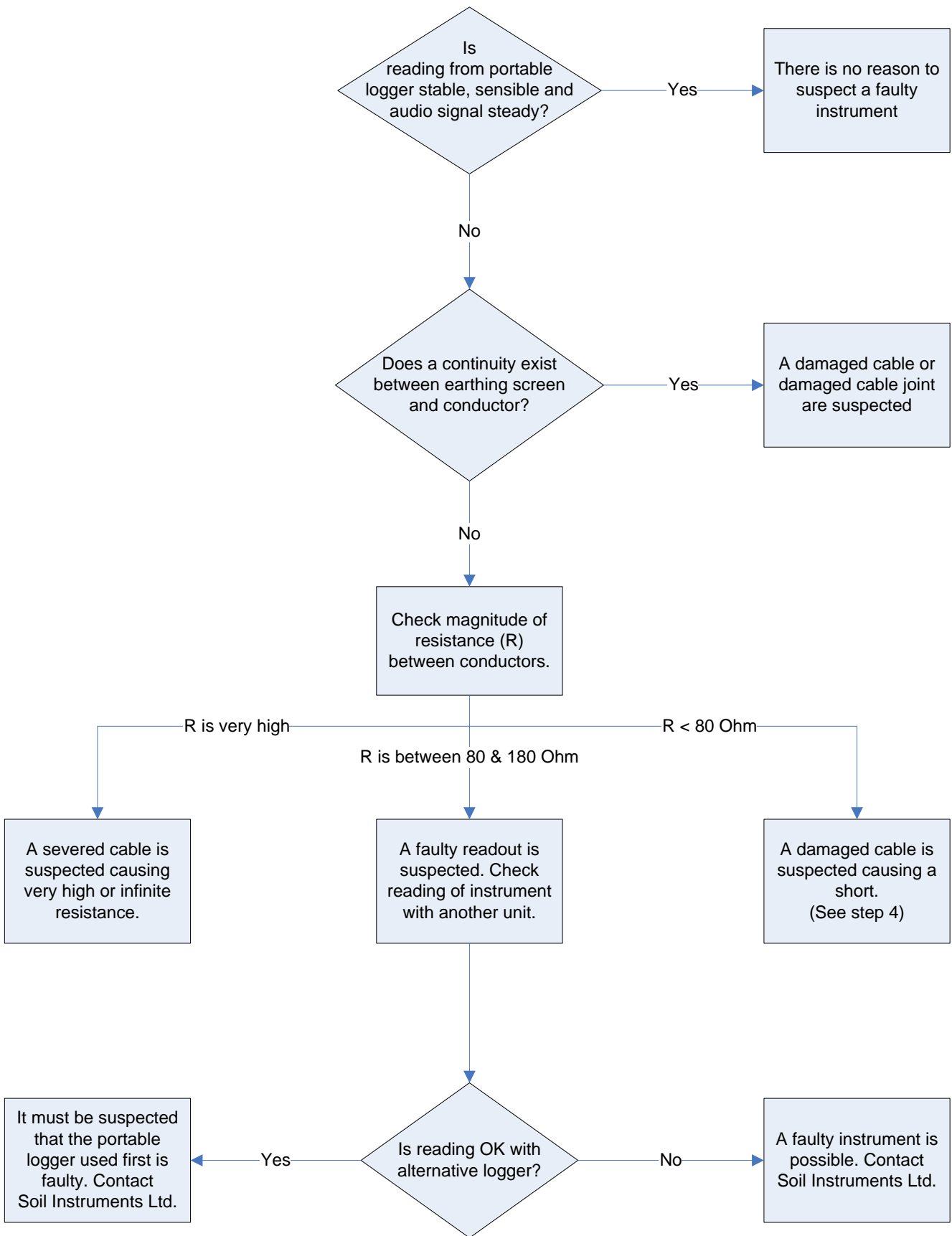



## Appendix C. CE Declaration

---



### EC Declaration of Conformity

**Soil Instruments Ltd.**, located at 34 Bell Lane, Uckfield, East Sussex, TN22, 1QL, United Kingdom.

We hereby declare that the devices described below are in conformity with the directives listed. In the event of unauthorised modification of any devices listed below, this declaration becomes invalid.

Type: STANDARD VIBRATING WIRE EMBEDMENT STRAIN GAUGE

Product Model: **ST4 Embedment VW Strain Gauge**

#### Relevant EC Directives and Harmonized Standards:

2004/108/EC Electromagnetic Compatibility directive, as amended by EN61326-1, ed3

The product(s) to which this declaration relates is in conformity with the essential protection requirements of 2004/108/EC Electromagnetic Compatibility directive, as amended by EN61326-1, ed3. The products are in conformity with the following standards and/or other normative documents:

**EMC: Harmonized Standards: EN 61326-1:2006 Lab Equipment, EMC**

IEC61000-6-3:2007 Emission standard for residential, commercial and light-industrial environments

IEC61000-4-2:2008 Electrostatic discharge immunity test

IEC61000-4-3:2006 Radiated, radio-frequency, electromagnetic field immunity test

IEC61000-4-4:2012 Electrical fast transient/burst immunity test

IEC61000-4-5:2005 Surge immunity test

IEC61000-4-6: 2008 Immunity to conducted disturbances, induced by radio-frequency fields

IEC61000-4-11:2004 Voltage dips, short interruptions and voltage variations immunity tests

I hereby declare that the equipment named above has been designed to comply with the relevant sections of the above referenced specifications. The items comply with all applicable Essential Requirements of the Directives.

Philip Day

Date: 22/02/2016

A handwritten signature in black ink, appearing to read "Philip Day", is written over a solid black horizontal line.

**Manufacturing Manager,**

Issued in: Bell Lane, Uckfield, East Sussex, TN22, 1QL, United Kingdom







Bell Lane, Uckfield, East Sussex

TN22 1QL, United Kingdom

**t:** +44 (0) 1825 765044

**e:** [info@soilinstruments.com](mailto:info@soilinstruments.com)

**w:** [www.soilinstruments.com](http://www.soilinstruments.com)

Soil Instruments Ltd. Registered in England. Number: 07960087. Registered Office: 3rd Floor, Ashley Road, Altrincham, Cheshire, WA14 2DT